



## Nova estação de Exaustão Móvel



**ANVISA**  
Agência Nacional  
de Vigilância Sanitária



**HAYASHI**  
SYSTEM



ASSOCIAÇÃO  
BRASILEIRA  
DE NORMAS  
TÉCNICAS



ASHRAE  
Associate  
Society  
Alliance

A plataforma de culinária móvel Hayashi Tecnologia de Exaustão oferece uma experiência de catering única, permitindo que os chefs preparem alimentos diante dos convidados.

Este sistema plug and play é altamente eficiente e independente, incorporando a expertise da empresa no campo de ventilação e controle de emissões.



A mobilidade oferecida pela plataforma permite que os chefs fiquem mais próximos dos hóspedes, resultando em maior vendas devido à experiência de ingredientes frescos e culinária ao vivo.

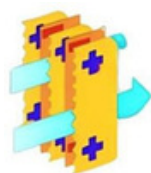

Lâminas com  
tecnologia  
Hayashi

A Linha Buffet de Exaustão Móvel de Ar Anti-Odores oferece tripla filtragem para reduzir odores e vapor durante o cozimento.

Com tecnologia anti-odores de ar e sistema de compensação incorporado, inclui estações de exaustão de bancada e recirculação, além de soluções inovadoras para profissionais de alimentação e cozinhas profissionais no Brasil e no exterior.

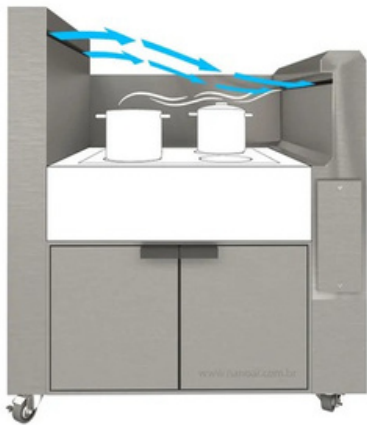

A linha também apresenta tecnologia de exaustão integrada, de encosto ou de centro, com rodízios para fácil movimentação e opções de luminárias. Ideal para uso em salões, festas, áreas de lazer e jardins, onde os clientes podem desfrutar de alimentos frescos sem preocupações com odores indesejados.

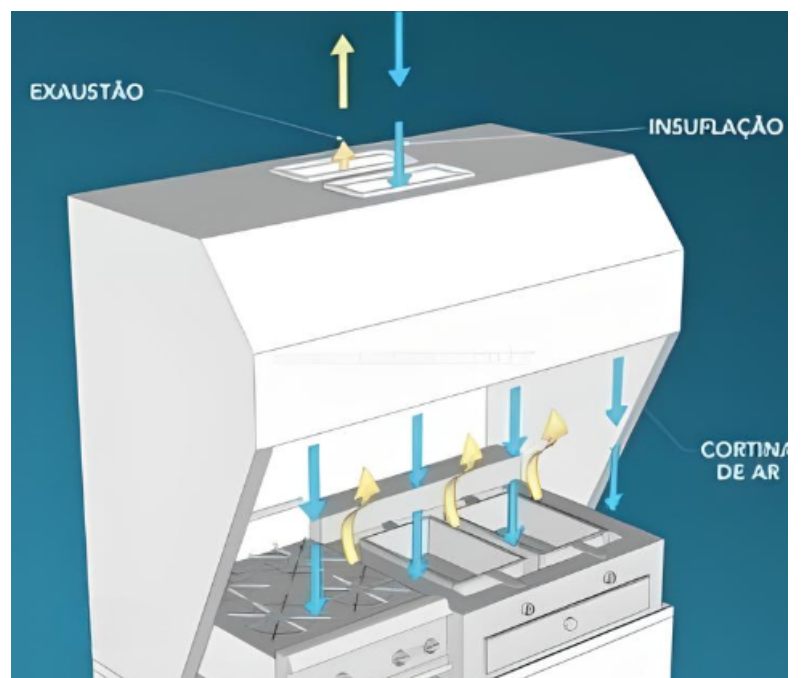

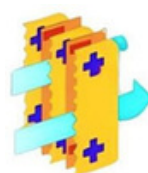
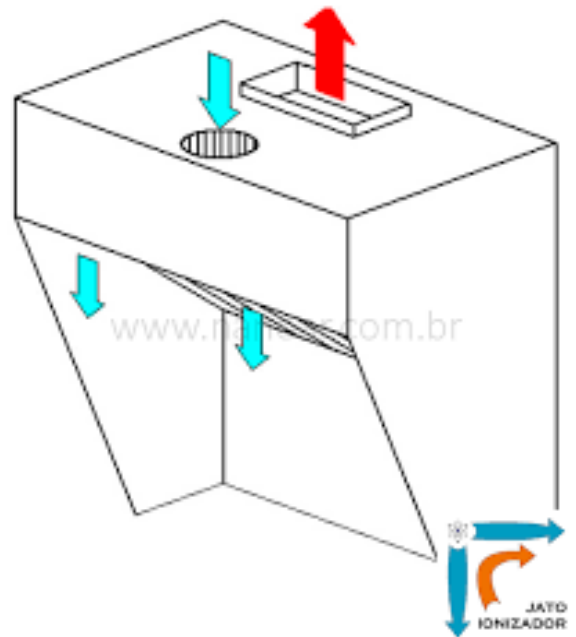
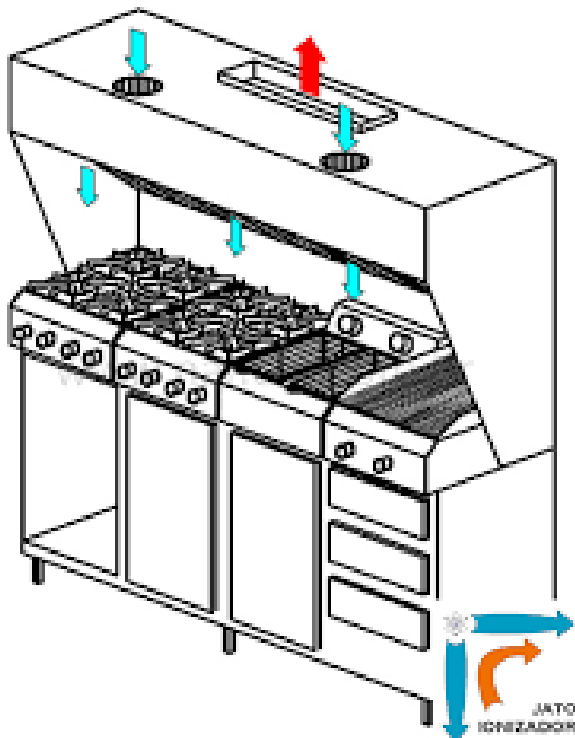
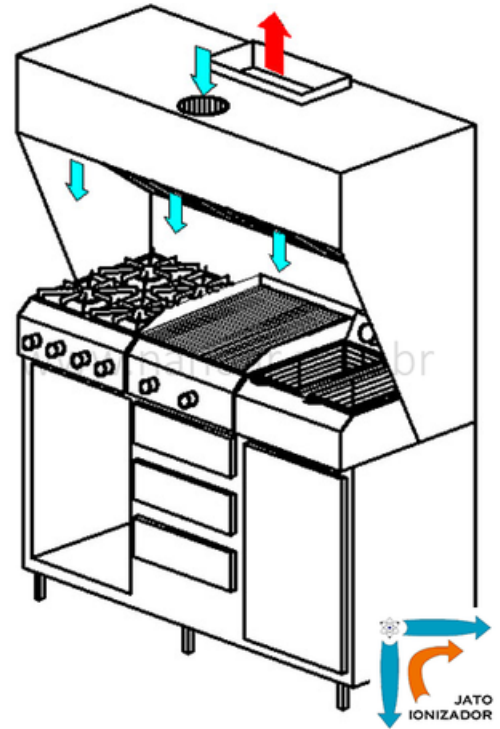
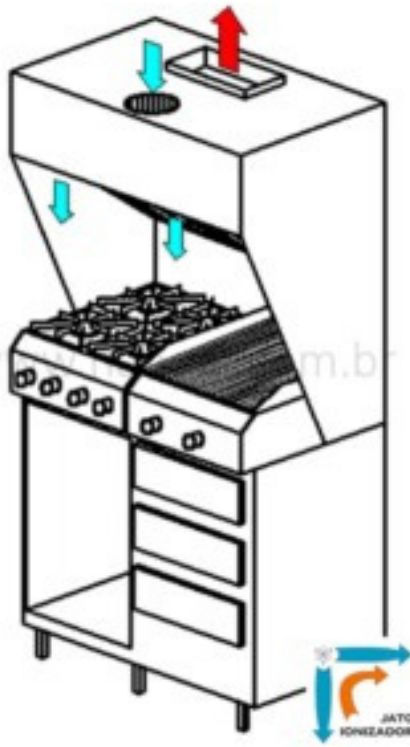

Lâminas com tecnologia Hayashi



Se interessou por algum produto?

Entre em contato conosco!

(11)932169701

Horário de Atendimento

Segunda à Sexta, 8h00 às  
17h00 Sábado, 8h00 ao 12h00

Se preferir, visite nosso Showroom

Rua João de Sousa Dias, 412- Campo Belo, São Paulo

Todos os produtos ARWEK possuem direitos autorais

**ARWEK**

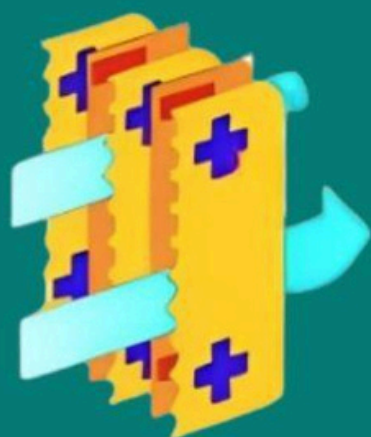

Lâminas com  
tecnologia  
Hayashi